

RACE	
TRACK NAME	
CITY / COUNTRY	
DATE	

TEMPERATURE	AIR	TRACK	
QUALIFYING POSITION	BEST LAP TIME SEC	FINAL POSITION	RACE LENGTH MIN
TRACK CONDITION	<input type="checkbox"/> CARPET	<input type="checkbox"/> ASPHALT	
	<input type="checkbox"/> TECHNICAL	<input type="checkbox"/> MIXED	<input type="checkbox"/> FAST
TRACTION	<input type="checkbox"/> LOW	<input type="checkbox"/> MEDIUM	<input type="checkbox"/> HIGH

TRANSMISSION	
GEAR DIFF OIL CST	NUMBER OF GEARS 2 4

PINION	T	SPUR GEAR	T
FINAL DRIVE RATIO			

SHOCK SET	
<input type="checkbox"/> PDS FRONT	<input type="checkbox"/> PDS REAR

FRONT	OIL	REAR
CST		CST
	SPRING	
mm	HOLES / DIAMETER	mm
%	REBOUND	%

ANTI-ROLL BAR	
FRONT	REAR
mm	mm

TIRES			
ADDITIVE TIMING			
ADDITIVE			
FL	FR	RL	RR
TREATED AREA			

BODY MOUNT DISTANCE	
mm	

BODY	WING
------	------

NOTE

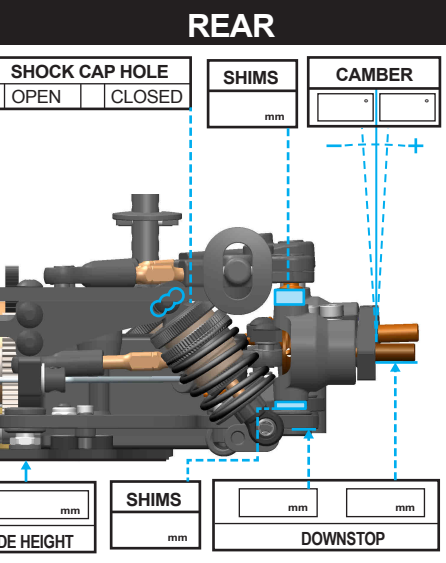
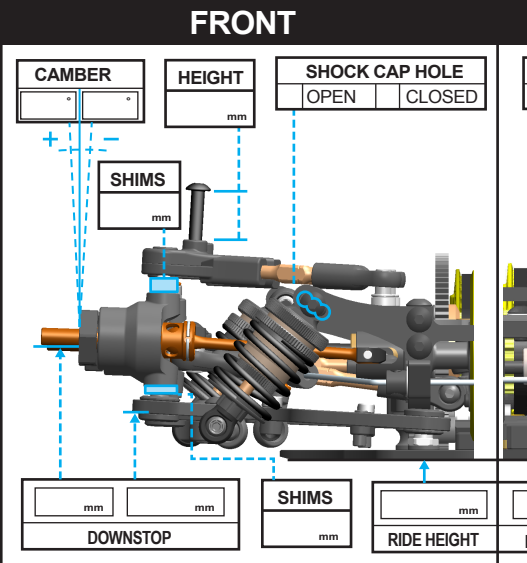
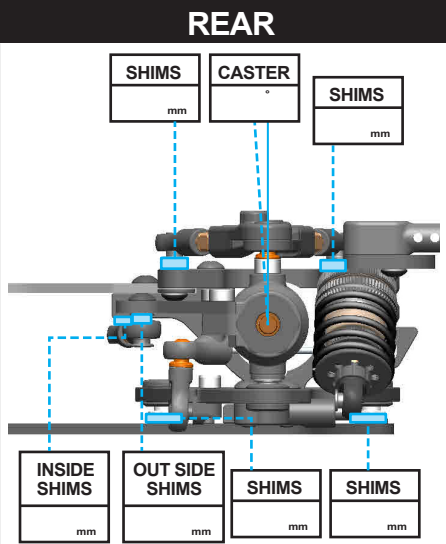
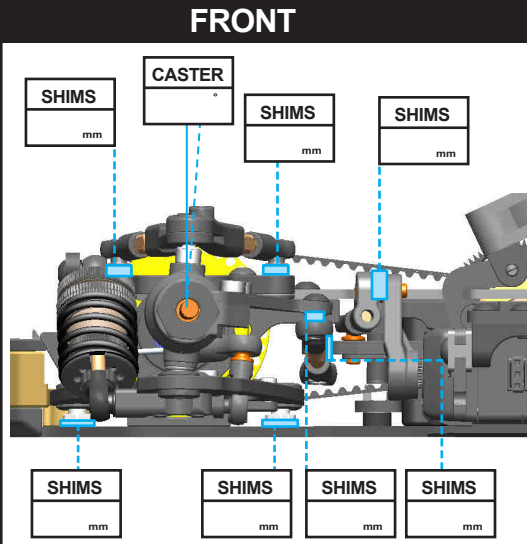

CHASSIS SETUP

